

SOLAR WATER HEATING
SYSTEMS CERTIFICATION AND
RATING



SRCC OG-300

CERTIFIED SOLAR WATER HEATING SYSTEM

SUPPLIER: ACR Solar International
5840 Gibbons Dr.
Suite G
Carmichael, CA 95608
(916) 481-7200
(916) 481-7203 Fax
(888) 801-9060

SYSTEM NAME: Skyline System 5
SYSTEM TYPE: Direct Forced Circulation

Description: Glazed Flat-Plate Collector, Photovoltaic Panel Controller, Tank Wrap Around Heat Exchanger with a Double Wall and Positive Leak Detection, No Load Side Heat Exchanger, Fluid Class II, Freeze Tolerance: -47.7 C (-54 F), Gas Auxiliary Tank

| System Model Name | Cert 300-# | Cert Date | Collector Panel Manufacturer | Collector Panel Name | Total Panel Area (Sq-m) | Total Panel Area (Sq-ft) | Solar Tank Vol (l) | Solar Tank Vol (gal) | Aux Tank Vol (l) | Aux Tank Vol (gal) | SEF |
|-------------------|------------|-----------|------------------------------|----------------------|-------------------------|--------------------------|--------------------|----------------------|------------------|--------------------|-----|
| 200152C80EX2TG | 2001019A | 12/9/2002 | ACR Solar International | 20-01 | 3.7 | 40.1 | 303 | 80 | 189 | 50 | 0.9 |

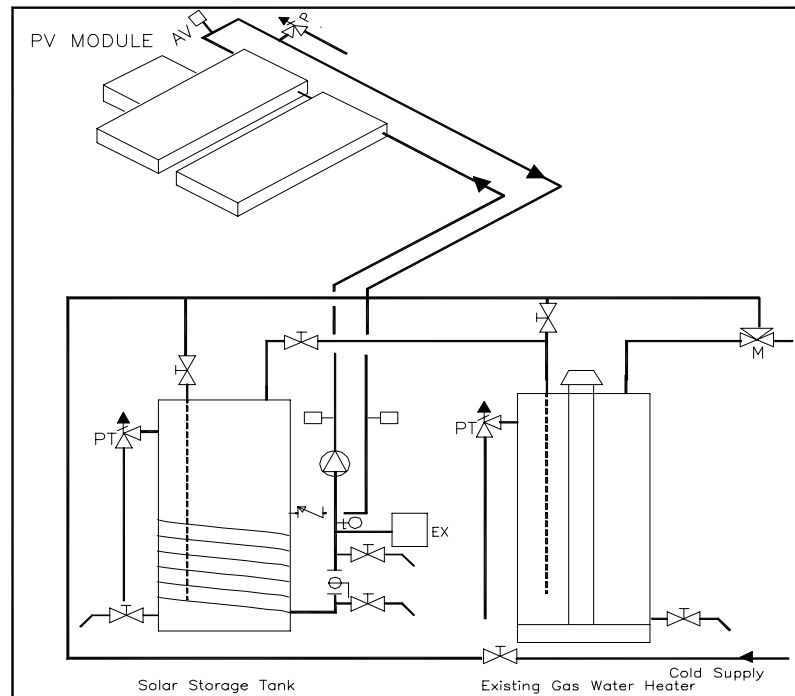

OG300 System Reference: 2001019A

April 2008

Certification must be renewed annually. For current status contact:
SOLAR RATING & CERTIFICATION CORPORATION

c/o FSEC ♦ 1679 Clearlake Road ♦ Cocoa, FL 32922 ♦ (321) 638-1537 ♦ Fax (321) 638-1010